



# EMERGENCY PHONE MOUNTS

## J&R – Solar Powered Emergency Phone Tower

### Description

JR321-SC-SP-GSM Solar Emergency Phone Tower is an ideal security solution for remote and high-risk areas. Standing over nine feet tall, this vandal-resistant tower serves as a great deterrent to crime. An always-lit LED Blue Light mounted atop the tower provides high visibility and gives passers-by a sense of security. Patrons can call emergency personnel with a simple push of a button. At the same time, the LED Blue Light begins to flash, attracting attention to the location. The Emergency Phone faceplate is illuminated at all times for clear visibility during the night.

JR321-SC-SP-GSM Solar Emergency Phone Tower offer greater deployment flexibility with wireless, solar, surveillance and day/night charge options. They are often used at university and college campuses, parking facilities, shopping malls, medical centers, industrial campuses, transit facilities and remote locations where local power is not available.

### Features

1. Solar panels and batteries are sized according to the installation location. A charger, batteries and other equipment mount inside the tower.
2. Attention-getting LED Blue Light is included and mounted atop the unit. The LED Blue Light is continuously lit and flashes for duration of a call when "EMERGENCY" button is pressed to draw attention to the unit.
3. LED Blue Light is housed in a protective poly carbonate housing
4. Emergency Phone face plate is made of brushed stainless steel with security screw.
5. Vandal-resistant structure and coating designed to resist extreme weather conditions
6. A variety of signage, graphics and color choices are available
7. ADA-compliant

### Specifications

Built-in auto-dialer, 2-way hands-free communication, with built-in speaker and microphone, Auto-answer allows security to monitor and initiate calls with Emergency Phone

Vandal resistant brushed stainless steel faceplate and metal button, Circuit boards are conformally coated for water protection,

Dimensions (W x D x H):	12.0 x 10.0 x 127.9 in. (305 x 254 x 3249 mm) including mast with 2 in. radius corners
Weight:	(135kg) for empty tower
Construction:	0.25 in. steel
Coating:	High-gloss, multi-layer, corrosion-inhibitive system with resistance to graffiti protection
Colors:	Safety Red is standard. Available in custom colors.
Signage:	3.25 in. high reflective white "EMERGENCY" lettering with wide-angle visibility is standard. Available in custom colors, lettering and graphics.
Lighting:	LED Blue Light: 209 lumens peak, 78 flashes per minute, 70% of initial lumens after 50,000 hours of operation
Power:	9.0 watts, 12-24VDC
Mounting:	Mounts into concrete foundation using included hardware (shipped in advance). Mounting options available for pre-poured parking decks.
Warranty:	5-year warranty on tower (2-year warranty on electronics)



# J&R – Solar Powered Emergency Phone Tower

## Dimensional Diagram

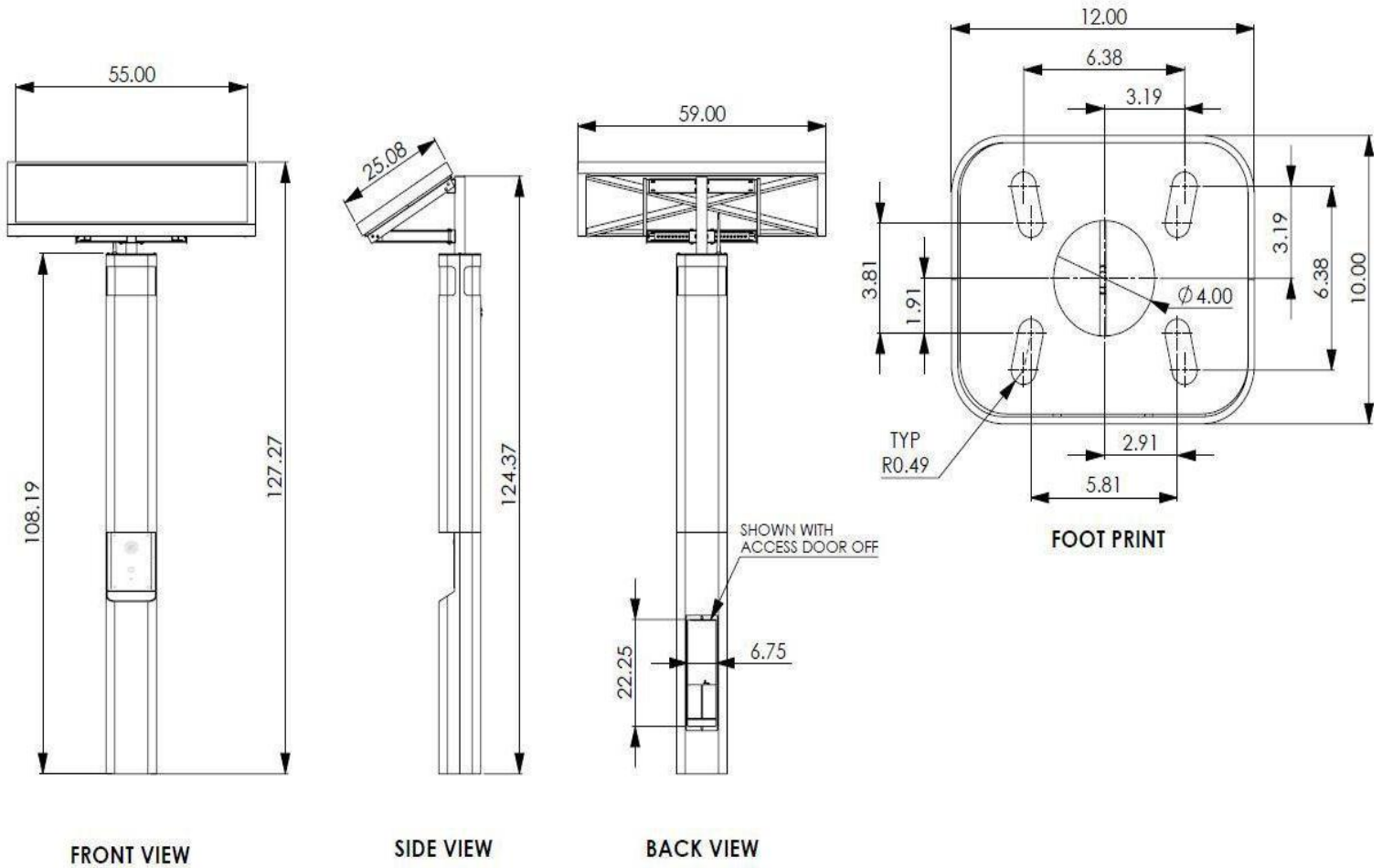

All dimensions are in inches and are provided for reference only.